

NOTES:

1. MATERIAL: FIBERGLASS REINFORCED POLYMER (FRP)
2. WEIGHT: COLUMN: 57 Lbs.
CAP: 2.5 Lbs.
BASE: 4.5 Lbs.
3. MATERIAL THICKNESS.
COLUMN: 3/8"
4. INSIDE DIAMETER AT TOP OF COLUMN: 5 1/2"
5. OUTSIDE DIAMETER AT TOP OF COLUMN: 6 1/4"
6. INSIDE DIAMETER AT BOTTOM OF COLUMN: 7"
7. OUTSIDE DIAMETER AT BOTTOM OF COLUMN: 7 3/4"
8. TAPER STARTS FROM BOTTOM OF COLUMN: 30"
9. FLUTES START FROM BOTTOM OF COLUMN: 11 1/2"
10. MAXIMUM LOAD BEARING WEIGHT: 10000 Lbs.
11. 16 FLUTES

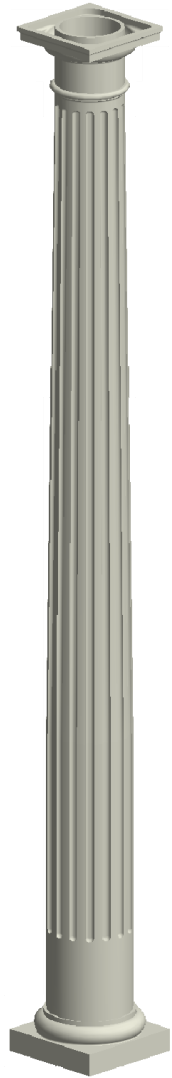

NOT TO SCALE

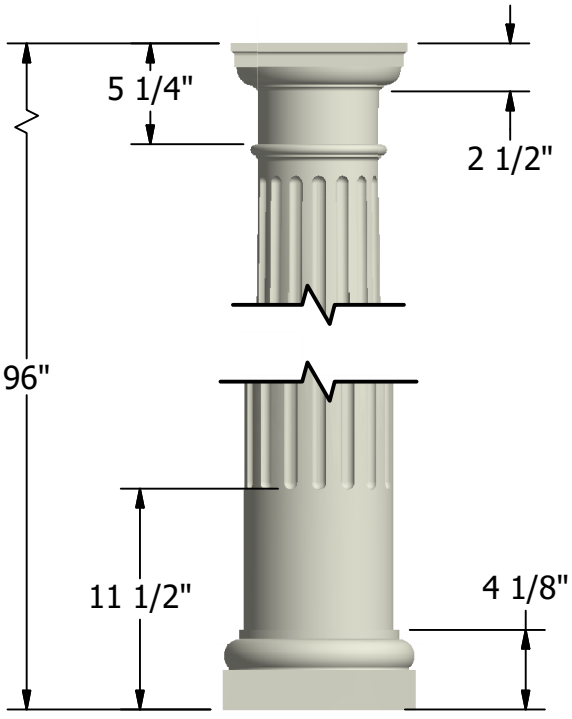
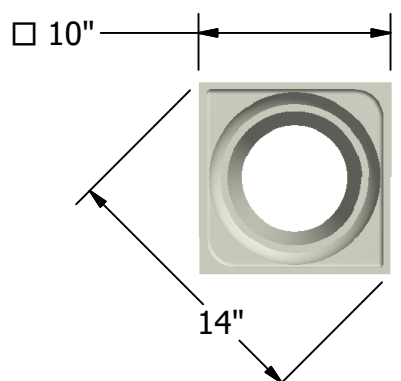

DRAWN Bryan Daniels	5/16/2016
CHECKED	
QA	
DIMENSIONS ARE IN INCHES TOLERANCE: ± 1/4"	

FIRST CLASS
BUILDING PRODUCTS, INC.

TITLE Round Fluted Column Assembly 8" x 8'		
SIZE A	DWG NO FL0808	REV 03

First Class Building Products -bW
3600 Dallas Highway Suite 230-387
Marietta, GA 30064
Tel: 770-514-8141
Email: firstclassbp@gmail.com
www.firstclassbp.com

SCALE 1:10	SHEET 1 OF 1
---------------	--------------