

NOTES:

1. MATERIAL: FIBERGLASS REINFORCED POLYMER (FRP)
2. WEIGHT: COLUMN: 70 Lbs.  
CAP: 2.5 Lbs.  
BASE: 4.5 Lbs.
3. MATERIAL THICKNESS.  
COLUMN: 3/8"
4. INSIDE DIAMETER AT TOP OF COLUMN: 5 1/4"
5. OUTSIDE DIAMETER AT TOP OF COLUMN: 6 1/4"
6. INSIDE DIAMETER AT BOTTOM OF COLUMN: 6 1/4"
7. OUTSIDE DIAMETER AT BOTTOM OF COLUMN: 7 5/8"
8. TAPER STARTS FROM BOTTOM OF COLUMN: 42"
9. FLUTES START FROM BOTTOM OF COLUMN: 12"
10. MAXIMUM LOAD BEARING WEIGHT: 10000 Lbs.
11. 16 FLUTES

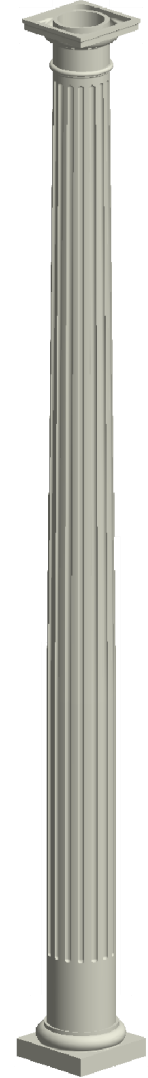
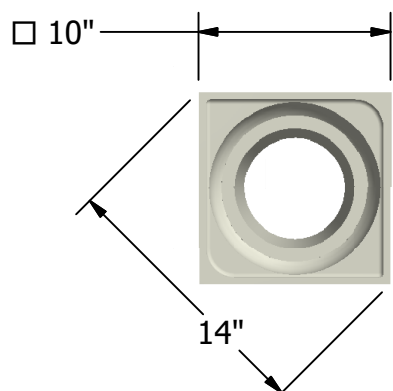
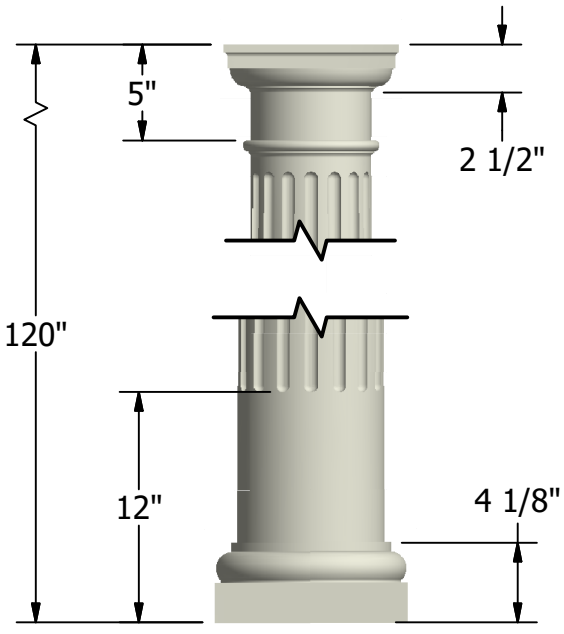
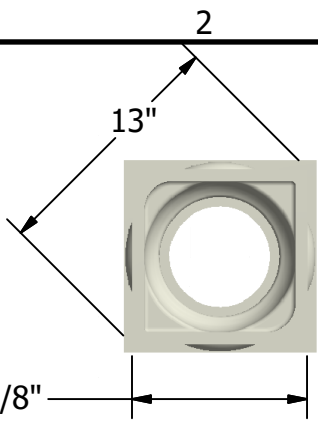

NOT TO SCALE

DRAWN Bryan Daniels	5/16/2016
CHECKED	
QA	
DIMENSIONS ARE IN INCHES	
TOLERANCE: ± 1/4"	

**FIRST CLASS**  
BUILDING PRODUCTS, INC.

TITLE  
Round Fluted Column Assembly  
8" x 10'

SIZE A	DWG NO FL0810	REV 03
SCALE 1:10	SHEET 1 OF 1	

First Class Building Products -bW  
3600 Dallas Highway Suite 230-387  
Marietta, GA 30064  
Tel: 770-514-8141  
Email: firstclassbp@gmail.com  
www.firstclassbp.com