

NOTES:

1. DIMENSIONS WITHIN THE PARENTHESES ARE METRIC UNITS (millimeters) or (Kg=Kilograms)
2. MATERIAL: FIBERGLASS REINFORCED POLYMER (FRP)
3. WEIGHT. COLUMN:  
CAP:  
BASE:
4. MATERIAL THICKNESS.  
COLUMN: 3/8" (9.5)
5. INSIDE DIMENSION AT TOP OF COLUMN: 12 5/8" (330.7)
6. OUTSIDE DIMENSION AT TOP OF COLUMN: 13 3/8" (339.7)
7. INSIDE DIMENSION AT BOTTOM OF COLUMN: 13 3/8" (339.73)
8. OUTSIDE DIMENSION AT BOTTOM OF COLUMN: 14 1/8" (358.8)

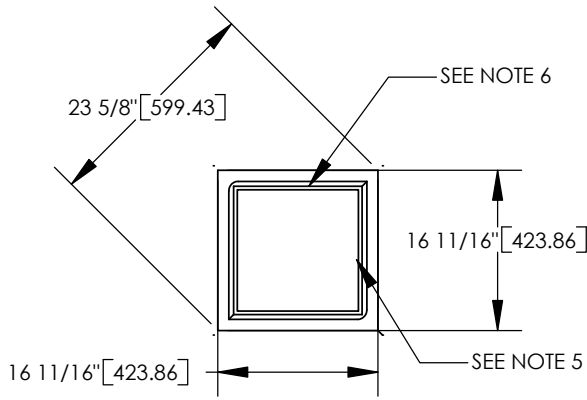

SQUARE TUSCAN  
1 3/4" 1 3/4" 14" CAP

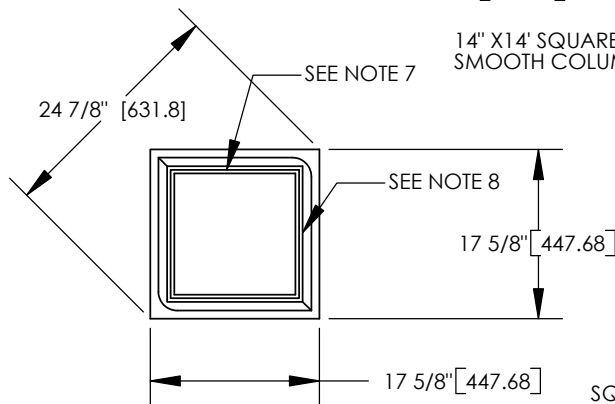
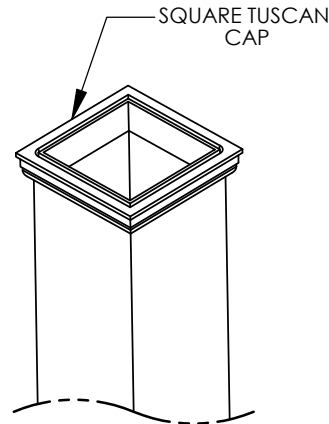
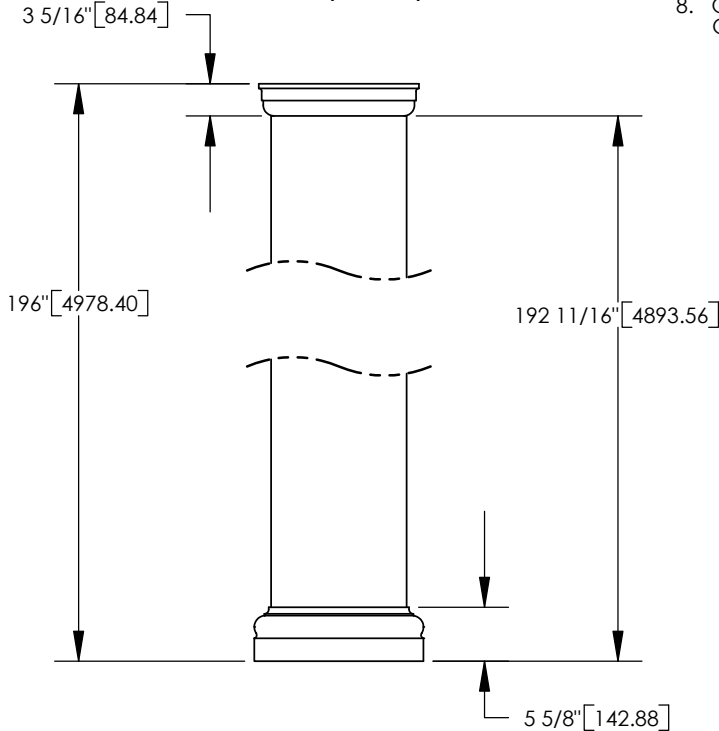

SQUARE TUSCAN  
14" BASE

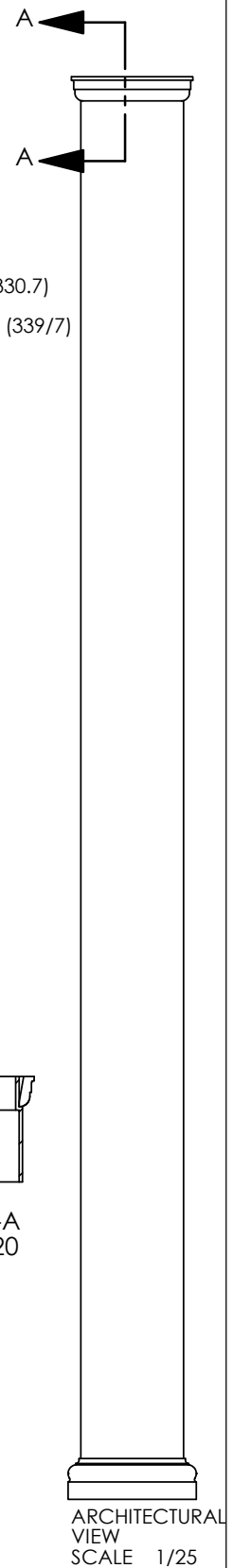
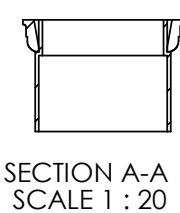
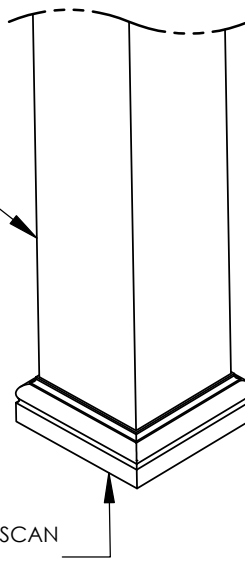

**FIRST CLASS  
BUILDING PRODUCTS**

888-514-8141

		DIMENSIONS ARE IN INCHES (mm) TOLERANCES: FRACTIONAL ± 1/4" ANGULAR: MACH ± BEND ± TWO PLACE DECIMAL ± THREE PLACE DECIMAL ±		
		MATERIAL		
NEXT ASSY	USED ON	FINISH		
APPLICATION		DO NOT SCALE DRAWING		

	NAME	DATE
DRAWN	SOF	05/05/08
CHECKED	RK	
ENG APPR.	RK	
MFG APPR.	RK	
Q.A.	RK	
COMMENTS:		

© COPYRIGHT		
14"X 14' TUSCAN SQUARE SMOOTH COLUMN ASSEMBLY		
SIZE <b>A</b>	DWG. NO.	REV. 02
SCALE: 1/20	WEIGHT:	SHEET 1 OF 1