

- NOTES:
1. DIMENSIONS WITHIN THE PARENTHESES ARE METRIC UNITS (millimeters) OR (Kg=Kilograms)
 2. MATERIAL: FIBERGLASS REINFORCED POLYMER (FRP)
 3. WEIGHT. COLUMN: 83Lb. (37.6 Kg)
CAP: 8Lb. (3.6 Kg.)
BASE: 15Lb. (6.8 Kg.)
 4. MATERIAL THICKNESS: 3/8" (9.5)
 5. MAXIMUM LOAD BEARING LIMITS: 14000 Lb. (6350.3 Kg.)

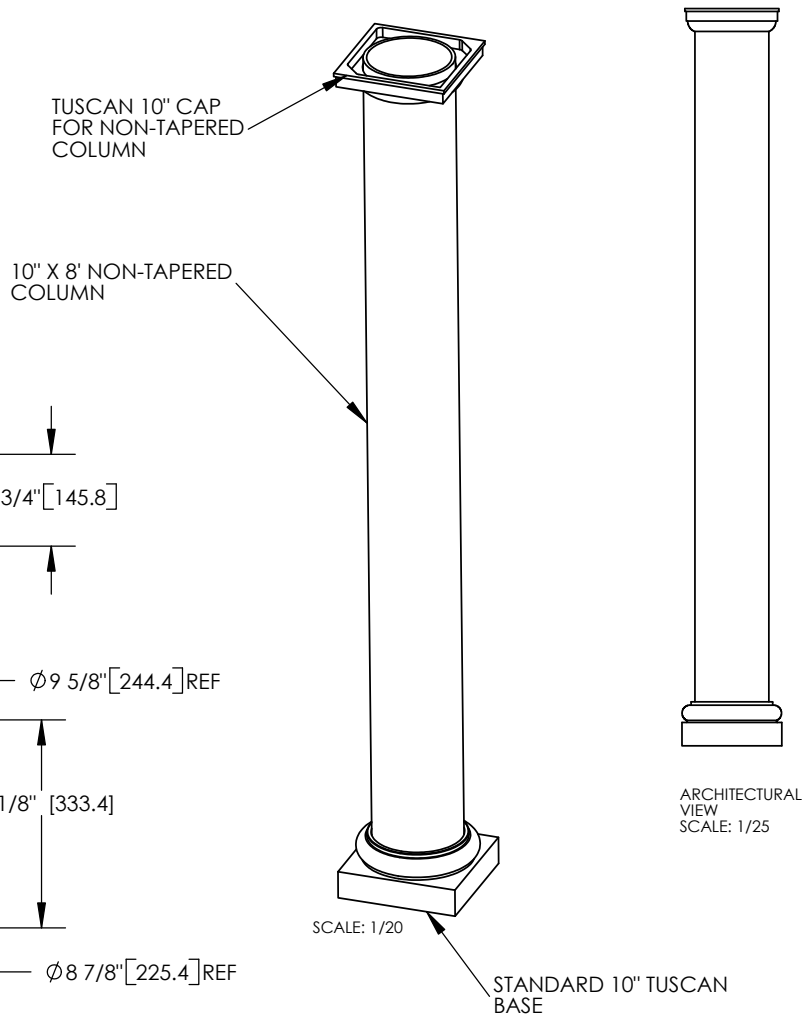
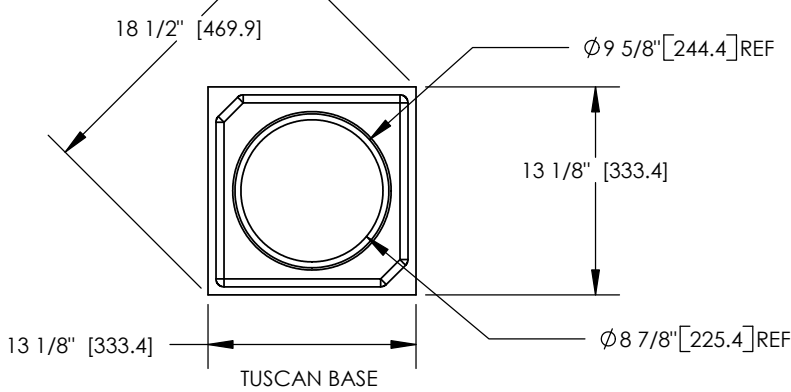
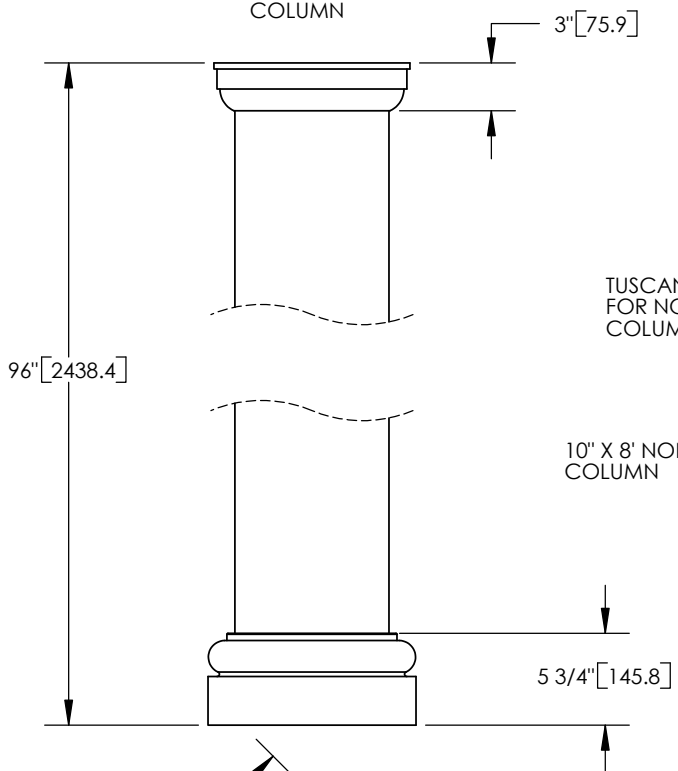

FIRST CLASS BUILDING PRODUCTS
888-514-8141

		DIMENSIONS ARE IN INCHES TOLERANCES: FRACTIONAL ± 1/8" ANGULAR: MACH ± BEND ± TWO PLACE DECIMAL ± THREE PLACE DECIMAL ±	NAME	DATE	©COPYRIGHT	
			DRAWN	SOF		05/05/08
			CHECKED	RK		
			ENG APPR.	RK		
			MFG APPR.	RK		
			Q.A.	RK		
		COMMENTS:				
NEXT ASSY	USED ON	FINISH				
APPLICATION		DO NOT SCALE DRAWING				
SIZE	DWG. NO.		REV.			
A			02			
SCALE: 1:12		SHEET 1 OF 1				

10" x 8" TUSCAN NON-TAPERED COLUMN ASSEMBLY